



Development of a Threshing Device for Pearl Millet

**Akinwonmi Ademola Samuel^{1*}, Kolawole Adenike Alice¹,
Seckley, Emmanuel Mawuli² and Adedotun O. Adetunla³**

¹Department of Mechanical Engineering, Ajayi Crowther University, Oyo, Nigeria.

²University of Mines and Technology, Tarkwa, Ghana.

³Department of Mechanical Engineering, University of Johannesburg, South Africa.

Authors' contributions

This work was carried out in collaboration between all authors. Author AAS designed the study, performed the statistical analysis, wrote the protocol, and wrote the first draft of the manuscript. Authors KAA and SEM managed the analyses of the study. Author AOA managed the literature searches. All authors read and approved the final manuscript.

Article Information

DOI: 10.9734/CJAST/2019/v33i130046

Editor(s):

(1) Dr. Maduikie Chiehiura Onwubiko Ezeibe, Professor, Department of Veterinary Medicine, Michael Okpara University of Agriculture, Umudike, Abia State, Nigeria.

(2) Dr. Hamid El Bilali, Centre for Development Research, University of Natural Resources and Life Sciences (BOKU), Vienna, Austria.

Reviewers:

(1) Jackson Akpojar, University of Africa, Nigeria.

(2) Kiran D. Devade, Pune University, India.

(3) Oludele Adebayo Adeyefa, University of Ibadan, Nigeria.

Complete Peer review History: <http://www.sdiarticle3.com/review-history/46538>

Original Research Article

Received 23 October 2018

Accepted 30 January 2019

Published 27 February 2019

ABSTRACT

Millet is a high energy and nutritious food recommended for the health and well-being of infants, lactating mothers and elderly people. Threshing of this crop still poses a lot of problems to local farmers. To make millet farming integral in Ghana, engineers are making concerted efforts to produce simple farm implements. This will complement other measures adopted by other stakeholders to ensure that there is food security. This paper therefore presents a community based millet thresher to reduce the burden farmers go through in threshing pearl millet. The millet thresher has a thresher welded to a steel shaft and then supported on a frame. Connected to the thresher are; an input mounted on the thresher and an output fitted to the exit of the thresher. The output comprises a sieve and a tray. A centrifugal fan supported on the frame supplies air that winnows the threshed grain coming out of the tray and the cleaned millet grains fall into a collector. The millet thresher mainly employs the effects of friction (taking advantage of the fact that millets can be effectively threshed by rubbing the panicles on a rough surface) for threshing. Results show that the

*Corresponding author: E-mail: ademost2003@yahoo.co.uk, aadedotun@uj.ac.za;

thresher rotates in the anticlockwise direction at a speed of 950 revolutions per minute with shaft diameter of 30.88 mm calculated from the equivalent torque. The millet thresher would reduce the long laborious hours spent in threshing and improve the quality of the grains since the possibility of the wind introducing foreign materials into the millet is reduced.

Keywords: Threshing; pearl millets; local farmers; grains; centrifugal fan.

1. INTRODUCTION

Millets are in the family of cereals grown globally with differential importance across continents and within regions of the world. They form a diverse group of small grains cultivated in diverse and adverse environments, mostly in the dry, semi-arid to sub-humid drought-prone agro ecosystems [1]. Millet is one of the oldest human foods and believed to be the first domesticated cereal grain [2]. It is consumed at breakfast, lunch and supper, and its products demand is very high; 62 – 84% eating it in the form of thin (bouillie and furra) and thick (tuwo/to) porridges and up to 80% consuming it as couscous in Senegal. Millets are also malted or fermented to produce both alcoholic and non-alcoholic beverages such as pito (prepared in northern Ghana). Millets are high energy and nutritious foods recommended for the health and well-being of infants, lactating mothers, elderly and convalescents [1]. The early millet mature within 90 to 110 days and the late millet mature within 120 to 140 days [3]. According to [4] Millet grows on a panicle consisting of a stalk, florets and the grain. In threshing, the florets are stripped off from the stalk and the grains from the florets. Women in the Upper East region of Ghana still employ the traditional method of threshing the millet using a mortar and a pestle or a pestle and dents on large rock surfaces. Commercial millet farmers sometimes use tractors as thresher. Fig. 1 shows some types of millets.

It was reported that the combine harvester could be used to harvest grain crops and combines the three separate operations (reaping, threshing and winnowing) into a single operation [5]. Among the crops harvested with a combine harvester are wheat, oats, rye, barley, corn (maize), soybeans and flax [6] in their invention with a US (United States) Patent Number US20100298037 presented a pedal-operated threshing machine. Some of the existing designs have no device for winnowing the threshed grain. Another invention with US (United States) patent number 5803807 employs a rotating concave mechanism [7]. A medium-scale thresher–

cleaner for legumes was tested on cowpeas [8]. The equipment has a conveyor, thresher fan and cleaning units. According to [9], the threshing unit is of the axial flow type. He also developed local machine model to suit threshing and separating faba bean crop. They determined the effect of cylinder speed and feed rates during threshing faba bean variety. Agricultural activities in Africa particularly in the rural communities are labour intensive. Ancient and ineffective farm implements are still in use. Not only does this phenomenon make this profession a dirty occupation, it also portrays it (the profession) as tiresome and none rewarding. These practices are in sharp contrast to the level of technological developments that characterize the other sectors of the economy of communities and nations. Millet processing especially threshing fits perfectly into this rather unfortunate scenario. In northern Ghana as well as other parts of Africa where millet is grown, threshing is done using a mortar and a pestle, a pestle and dents on large rock surfaces or beating the millet hipped on the ground. Winnowing is done using calabashes and baskets in the open space for the supply of air flow. This certainly does not befit the status of the modern day farmer who definitely applies modern scientific methodology to maximize farm output. To make (millet farming integral) in Ghana an alternative occupation rather than the last resort, concerted efforts should be made by (mechanical and agricultural engineers) to make simple farm implements to complement other measures adopted by other stake holders, this will tend to ensure food security. This paper proposes a community based millet thresher as one such intervention to reduce the burden farmers go through in threshing pearl millet.

The objective of this paper is to improve on the design of a millet threshing machine by introducing a counter thresher on community scale to ease the stresses undergone by subsistent farmers using the traditional method. This will also improve the quality of the threshed grain by minimizing the quantity of foreign materials like stones and seeds of weeds as in the case of the traditional method.

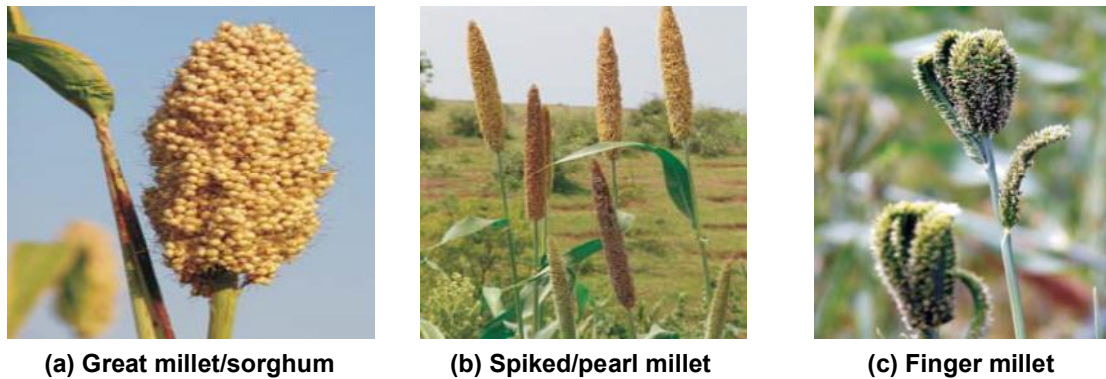

Fig. 1. Types of millet

2. MATERIALS AND METHODS

2.1 Mode of Operation of the Millet Thresher

The millet thresher operates on the principle of frictional effects. The operational sequence was illustrated for easy use. Malleable cast iron was selected for the design of the drum for castability, machinability, moderate strength, toughness, corrosion resistance and uniformity.

Standard design methods were used to design the weight (w) of the thresher (drum), the counter thresher, the shaft of the thresher, the Frame, the drive members and parameters. The power was calculated using a Design Factor of 1. The diameter of the shaft and the transmitted torque were determined by taking the maximum bending

moment and maximum shear force into consideration. The millet thresher has a thresher welded to a steel shaft and then supported on a frame. Connected to the thresher are; an input and an output fitted to the exit of the thresher. The output comprises a sieve and a tray. A centrifugal fan supported on the frame supplies air that winnows the threshed grain coming out of the tray. The cleaned millet grains fall into a collector (not shown). The fan and the thresher are driven by their respective drive members. The drive members are driven by an electric motor. Fig. 2 shows both the isometric drawing and the orthogonal views of the proposed thresher.

Fig. 3 shows the exploded view of the proposed design whilst Table 1 is the Parts List of the proposed design.

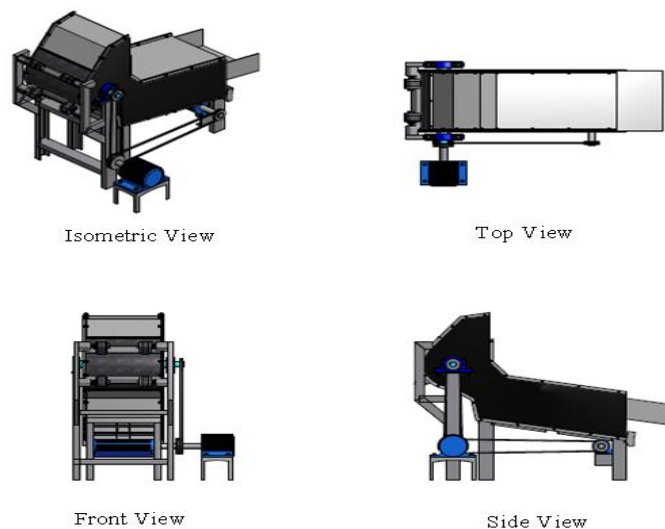

Fig. 2. Isometric and orthographic views of the millet thresher

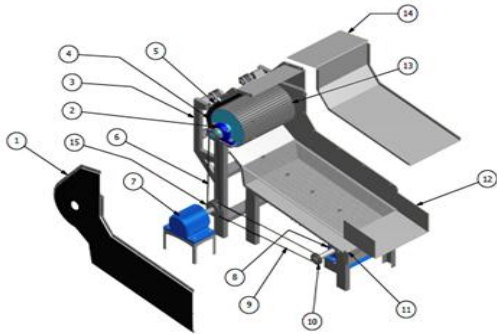

Fig. 3. Exploded view of the proposed design of the millet thresher

Table 1. Parts list of the proposed design

Part	Description	Quantity
1	Side cover	2
2	Plumber block housing a ball bearing	2
3	Frame	1
4	Counter thresher	1
5	Counter thresher	1
6	Drive member of thresher	1
7	Electric motor	1
8	Centrifugal fan	1
9	Drive member of fan	1
10	Pulley to fan	1
11	Output tray	1
12	Output sieve	1
13	Thresher	1
14	Top cover	1
15	Driver pulley	1

The millet thresher operates on the principle of frictional effects. The operational sequence is illustrated in Fig. 4.

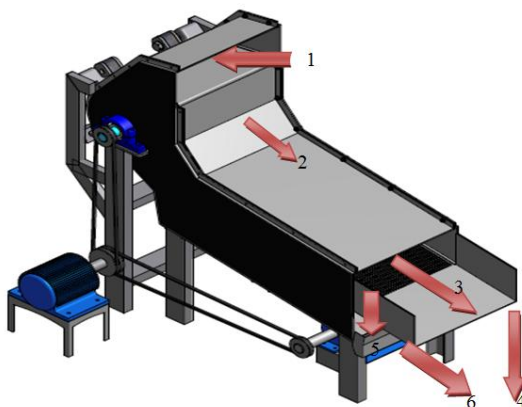

Fig. 4. Operational sequence of the proposed design of the millet thresher

The operator introduces about ten panicles into the thresher via the input in the direction of the arrow 1. The thresher rotates in the anticlockwise direction at a speed of 950 revolutions per minute. The rotational speed is transmitted by the belt from the electric motor. The surface of the thresher has rows of closely packed studs. These studs drag the panicles, rubbing them against the surface of the counter thresher. The surface of the counter thresher has latticed projections. The space between the thresher and the counter thresher immediately after the input is large enough to accommodate the size of a panicle. The space reduces progressively to the size of a grain immediately before exit. The florets are stripped off the stalks (some of the grains are also stripped off the florets) in the larger space. As the thresher rotates, the stalks are crashed into pieces due to their brittleness (This is a personal experience) and the other grains are stripped of their florets in the much smaller space. In the smaller space which takes about two-thirds of the entire threshing space (that is circumference-wise) the florets are closely rubbed by the thresher against the counter thresher. The grains are forced out of the floret due to the compressibility of the florets (This is a personal experience) or are ground due to their weakness. The grains are not crushed because they are harder and due to the flexibility of the rubber materials used for the surfaces of the threshers. The rubber materials absorb the impact hence the grains are not crushed. The studs on the thresher and the latticed projections on the counter thresher help to generate enough frictional force for these actions. The threshed grain and chaff then exit into the output with a sieve in the direction of the arrow 2. The grain and the finer chaff move into a trough below it and allows the much larger crushed stalk to exit the machine in the direction of the arrows 3 and 4. The grains slide down the sloppy sieve and fall through the holes into the bottom trough by gravity. The grain and the finer chaff slide down the trough and pass through an exit attached to it and fall in the direction of the arrow 5. The fan, driven by the electric motor via the belt, blows air in the direction of the arrow 6. The air blows of the chaff in the direction of the arrow 6 and the cleaned grains fall in the direction of the arrow 5 into a container (not shown) due to their much heavier weight.

2.2 Design of the Thresher

The thresher is a cylindrical drum mounted on a rotating shaft. The drum is made of malleable

cast iron with an outer rubber hollow cylinder screwed onto its surface. Malleable cast iron was selected for the design of the drum because of the following desirable properties: Castability, machinability, moderate strength, toughness, corrosion resistance and uniformity since all castings are heat-treated [10]. The diameter of

the drum is 200 mm, length is 400 mm and thickness is 5 mm. The outer cylinder is 10 mm thick. The outer surface of the outer cylinder which does the threshing has rows of closely packed studs each of height 5 mm. Fig. 5 and Fig. 6 show the drum and the outer cylinder respectively.

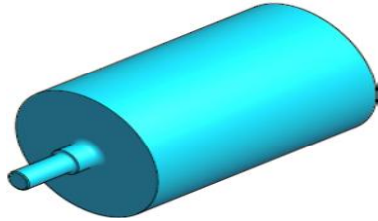

Fig. 5. Drum of thresher

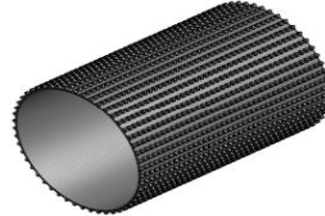

Fig. 6. Outer cylinder of thresher

Weight (W) of the Thresher (Drum)

The weight of the thresher drum is given as:

$$W = \rho \times V \times g \tag{1}$$

where,

ρ is density of the drum material
 V is volume of the drum material
 g is acceleration due to gravity

$$\begin{aligned} \rho &= \Sigma(\text{percentage of each element} \times \text{density of each element}) \\ &= (0.026 \times 2.3) + (0.016 \times 2.33) + (0.002 \times 7.4) + (0.0004 \times 2.3) + \\ &\quad (0.0018 \times 1.8) + (0.9538 \times 7.9) \text{ g/cm}^3 \\ &= 7.65106 \text{ g/cm}^3 \\ &= 7650 \text{ kg/m}^3 \end{aligned} \tag{2}$$

The volume of the hollow drum is given as;

$$\text{Volume (V}_H) = (\pi R^2 H - \pi r^2 H) \tag{3}$$

The volume of each end cover of the drum is given as;

$$\text{Volume (V}_D) = (\pi R_1^2 H_1 - \pi r_1^2 H_1) \tag{4}$$

where,

R is the outer radius of the drum
 r is the inner radius of the drum
H is the height (length) of the drum
 R_1 is the outer radius of the end covers of the drum
 r_1 is the inner radius of the end covers of the drum
 H_1 is the thickness of the end covers of the drum

$R = 0.1 \text{ m}$
 $r = 0.095 \text{ m}$
 $H = 0.39$
 $R_1 = 0.1 \text{ m}$
 $r_1 = 0.04 \text{ m}$ (for a shaft diameter of 40 mm)
 $H_1 = 0.005 \text{ m}$

Therefore,

$$\begin{aligned} V_H &= \{(\pi \times 0.1^2 \times 0.39) - (\pi \times 0.095^2 \times 0.39)\} \\ &= 1.1946 \times 10^{-3} \text{ m}^3 \\ V_D &= \{(\pi \times 0.1^2 \times 0.005) - (\pi \times 0.04^2 \times 0.005)\} \\ &= 1.3195 \times 10^{-4} \text{ m}^3 \end{aligned}$$

From equation 1, the weights of the hollow drum and its end covers are calculated as;

$$\begin{aligned} \text{The weight of the hollow drum} &= 7650 \times 1.1946 \times 10^{-3} \times 9.81 \\ &= 89.6505 \text{ N} \end{aligned}$$

$$\begin{aligned} \text{The weight of each end cover} &= 7650 \times 1.3195 \times 10^{-4} \times 9.81 \\ &= 9.9024 \text{ N} \end{aligned}$$

2.3 The Counter Thresher Design

The counter thresher aids in threshing. It is a 10 mm thick malleable cast iron shaped in the form of half a cylinder into which the thresher is assembled [11]. It has two parts; the lower part (located before the exit to the output) has a smaller space between it and the thresher while upper part (located next to the input) has a much opened space between them. Fig. 7 shows the counter thresher. The more opened space is to cater for bigger sizes of the panicles which could be 2.54 cm or less. A 5 mm thick rubber is screwed onto its surface. The surface of the rubber has a latticed projection to complement the thresher in threshing the millet. Fig. 8 indicates threshing surface of the counter thresher.

Weight of the Counter Thresher

Considering the counter thresher as a perfect rectangle, its weight is given as;

$$\text{Weight} = \rho \times L \times B \times t \quad (5)$$

where,

$$L = \text{length} = 0.1015 \text{ m}$$

B = the breadth of the counter thresher = 0.42 m

t = thickness of the counter thresher = 0.01 m

But volume,

$$V_C = 0.1015 \times 0.42 \times 0.01 = 4.2630 \times 10^{-4} \text{ m}^3$$

Using equation (5), the weight of the counter thresher, W_C is calculated as;

$$\begin{aligned} W_C &= 7650 \times 4.2630 \times 10^{-4} \times 9.81 \\ &= 31.9923 \text{ N} \end{aligned}$$

The Shaft of the Thresher

Fig. 9 shows the shaft of the thresher. The shaft transmits the power from the drive member to the thresher. Medium carbon steel was selected for the shaft. Medium carbon steels offer a range of properties after quenching and tempering; hence have wide range of uses including manufacturing of shafts [12]. The shaft would therefore be able to withstand stresses and deflections. Also, steel is cheaper with a competitive modulus of elasticity compared to other material candidates.



Fig. 7. Counter thresher

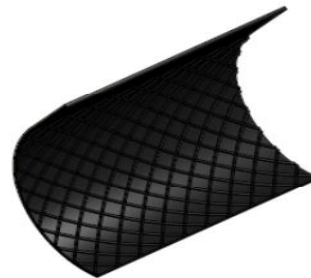

Fig. 8. Surface of counter thresher



Fig. 9. Shaft of the thresher

The Frame

This is made from steel channel (C3 × 6) bars. The support for the counter thresher is made of square steel bars. The frame offers support for the thresher, the output and the fan. The joints are welded to provide it with a permanent rigidity in operation. Fig. 10 shows the frame.

The Drive Members

The drive members (one shown in Fig. 11) are used to transmit the power from the motor to the respective shafts. The use of flexible machine elements for transmitting power simplifies the design of a machine and substantially reduces its cost [13]. Therefore, V-belts were used. According to [14], a V-belt drive has the following advantages:

1. The drive is positive, because the slip between the belt and the pulley groove is negligible
2. It provides longer life, 3 to 5 years
3. It can easily be installed and removed
4. The operation of the belt is quiet
5. The belt has the ability to cushion the shock when the machine is started

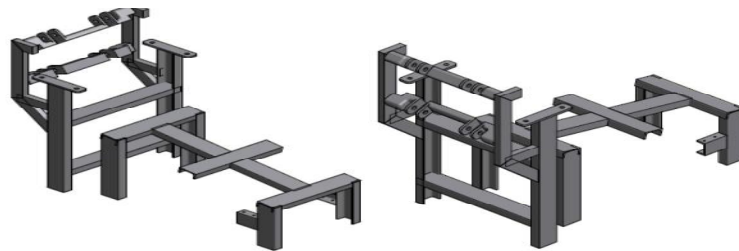

Fig. 10. Frame of the thresher



Fig. 11. Drive member

V-Belt Parameters

According to [13], the Pitch length L_p of the belt is given by:

$$L_p = \frac{\pi}{2}(d_1 + d_2) + 2X + \frac{(d_2 - d_1)^2}{4X} \quad (6)$$

where,

d_1 is the diameter of driven pulley = 0.12 m
 d_2 is the diameter of driver pulley = 0.095 m
 X is the centre distance between the driver and the driven shaft = 1 m (assumed)

$$L_p = \frac{\pi}{2}(0.095 + 0.12) + 2(1) + \frac{(0.12 - 0.095)^2}{4 \times 1} = 2.3378775 \text{ m} = 2337.8775 \text{ mm}$$

Also,

$$L_p = L + L_c \quad (7)$$

where,

L = inside diameter of the belt and L_c = length conversion dimension

Table 2 shows belt length conversion dimensions in millimetres.

Table 2. Length conversion dimensions in millimetres

Belt section	A	B	C	D	E
Quality to added	32	45	72	82	112

[13]

From Table 2, $L_c = 32$ mm for an A-section V-belt

$$\therefore L = L_p - L_c = 2337.8775 - 32 = 2305.8775 \text{ mm}$$

The actual centre to centre distance (X) is calculated as;

$$\begin{aligned} X &= 0.25 \left\{ \left[L_p - \frac{\pi}{2}(d_1 + d_2) \right] + \sqrt{\left[L_p - \frac{\pi}{2}(d_1 - d_2) \right]^2 - 2(d_1 - d_2)^2} \right\} \\ &= 0.25 \left\{ \left[2.282 - \frac{\pi}{2}(0.12 + 0.095) \right] + \sqrt{\left[2.282 - \frac{\pi}{2}(0.12 - 0.095) \right]^2 - 2(0.12 - 0.095)^2} \right\} = 1046.6825 \text{ mm} \end{aligned} \quad (8)$$

Angle of Wrap

$$\therefore V = \frac{\pi \times 0.095 \times 1200}{60} = 5.9690 \text{ m/s}$$

From [14]

$$\sin \alpha = \frac{d_1 - d_2}{2X} \quad (9)$$

where,

α , is the angle between the point at which the belt leaves the pulley and the normal.
 d_1 is the Diameter of Driven pulley = 0.12 m
 d_2 is the Diameter of Driver pulley = 0.095 m

X is the Centre distance of the driver and the driven shaft = 1046.6825 mm

$$\sin \alpha = \frac{0.12 - 0.095}{2 \times 1.0467}$$

$$\alpha = 0.6843^\circ$$

From [14], the angle of wrap is stated as:

$$\theta = (180^\circ - 2\alpha) \frac{\pi}{180} \quad (10)$$

where,

θ is the angle of wrap

$$\theta = (180^\circ - 2 \times 0.6843) \frac{\pi}{180} = 3.1177 \text{ rad.}$$

Speed (V) of the Belt

From [13], the speed V is given as;

$$V = \frac{\pi d_2 n_1}{60} \quad (11)$$

where,

n_1 is the speed of the electric motor's pulley which is 1200 rpm
 d_2 is the diameter of driver pulley = 0.095 m

Power Ratings of the Belt

From [13], the design power H_d is given as;

$$H_d = H_{nom} K_s n_d \quad (12)$$

where,

H_{nom} is the nominal power (that is the power of the electric motor, 2 kW)
 K_s is a service factor
 n_d is the design factor

For uniform drive and normal torque characteristics, K_s is 1 (Table 5)

A design factor of 1 is used.

$$\therefore H_d = 2.0 \times 10^3 \times 1 \times 1 = 2.0 \times 10^3 \text{ kW}$$

From [13], the allowable power per belt, H_a is given as;

$$H_a = K_1 K_2 H_{tab} \quad (13)$$

where,

K_1 is angle of wrap correction factor
 K_2 is belt length correction factor
 H_{tab} is the tabulated power

For an A-section V-belt running at a speed of 5.9690 m/s in a pulley of sheave diameter 95 mm, the tabulated power per belt H_{tab} is 0.7811 kW.

$K_1 = 1$ for an angle of wrap of almost 180° [13]
 $K_2 = 0.90$ for a belt length between 0.95 and 1.15 m [13]

$$\therefore H_a = 1 \times 0.90 \times 0.7811 = 0.7030 \text{ kW}$$

Number of Belts Required

For an A- section V-belt, K_C is 0.56, (Table 3)

From [13], the number of belts N_b required for the power transmission is given as:

$$\therefore F_C = 0.561 \left(\frac{5.9690}{2.4} \right)^2 = 3.4701 \text{ N}$$

$$N_b \geq \frac{H_d}{H_a} \quad (14)$$

For a V-belt made of rubber material, the effective coefficient of friction is 0.5123 [13]

where,

$$\therefore F_1 = 3.4701 + \frac{111.6877 \times \exp(0.5123 \times 3.0842)}{\exp(0.5123 \times 3.0842) - 1} = 144.1290 \text{ N}$$

H_a is the allowable power per belt
 H_d is the design power

Hence,

$$\therefore N_b \geq \frac{2.00}{0.7030} \geq 2.845 \text{ belts} = 3 \text{ belts (the next higher integer)}$$

$$F_2 = 144.1290 - 111.6877 = 32.4413 \text{ N}$$

The belt tension in reaction to flexural stresses in the tight side (F_{b1}) is given as;

Tensions in the Belts

$$F_{b1} = \frac{K_b}{d_2} \quad (19)$$

From [13],

where,

The tight side tension is;

$$F_1 = F_C + \frac{\Delta F \exp(f\theta)}{\exp(f\theta) - 1} \quad (15)$$

K_b is a V-belt parameter
 d_2 is the diameter of the driver pulley in inches = 3.7402 in.

and the loose-side tension is;

$$F_2 = F_1 - \Delta F \quad (16)$$

For an A- section V-belt K_b is 220 (Table 3).

where,

$$\therefore F_{b1} = \frac{220}{3.7402} = 58.8204 \text{ lbf} = 261.7508 \text{ N}$$

F_C is centrifugal tension
 ΔF is tension due to the transmitted torque
 θ is the angle of wrap in radians
 f is coefficient of friction

Belt tension in reaction to flexural stresses in the loose side (F_{b2}) is given as;

$$F_{b2} = \frac{K_b}{d_1} \quad (20)$$

The tension due to the transmitted torque (ΔF) is given as;

where,

$$\Delta F = \frac{H_d / N_b}{\pi d_2} \quad (17)$$

K_b is a V-belt parameter
 d_1 is the diameter of driven pulley in inches = 4.7244 in.

$$\therefore \Delta F = \frac{2000/3}{\pi \times 1200/60 \times 0.095} = 111.6877 \text{ N}$$

$$\therefore F_{b2} = \frac{220}{4.7244} = 46.5668 \text{ lbf} = 207.2223 \text{ N}$$

From [13], the centrifugal tension (F_C) is given as;

The total tension in the belt in the tight side is therefore given as;

$$F_C = K_C \left(\frac{V}{2.4} \right)^2 \quad (18)$$

$$T_1 = F_1 + F_{b1} \quad (21)$$

$$\therefore T_1 = 144.1290 + 261.7508 = 405.8798 \text{ N}$$

where,

K_C is a V-belt parameter
 V is the velocity of the belt

The total tension in the belt in the loose side is also given as;

$$T_2 = F_2 + F_{b2} \quad (22)$$

$$\therefore T_2 = 32.4413 + 207.2223 = 239.6636$$

Shaft Design Calculations

The diameter of the shaft is determined by taking the maximum bending moment and maximum shear force into consideration. The loading diagram is shown in Fig. 12.

Table 3. Some V-Belt parameters

Belt section	K_b	K_c
A	220	0.561

[Source: 13]

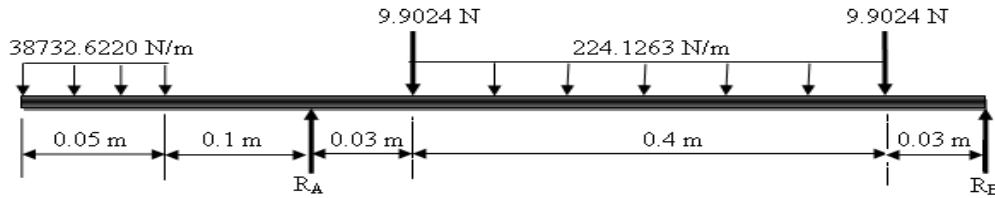

Fig. 12. Force diagram of the shaft of the thresher

From Fig. 12,

$R_A = 2517.6172 \text{ N}$ and $R_B = -471.5308 \text{ N}$

The shear force and the bending moments at the critical sections are calculated and presented in Table 4.

Table 4. Results of the shear forces and bending moments

At	Shear force(N)	Bending moment(N.m)
0.0	471.5308	0.0
0.03	481.4332	-14.1460
0.43	571.0837	-224.6491
0.46	580.9861	-242.0789
0.56	-1936.6311	-48.4158
0.61	0.0	0.0

Torque transmitted by the shaft

$$T = \frac{60 P}{2\pi N} \tag{23}$$

where,

- T is the transmitted torque
- P is the power of the motor
- N is the speed of the shaft

$$\therefore T = \frac{60 \times 2000}{2 \times \pi \times 950} = 20.1038 \text{ Nm}$$

From [14],

The equivalent torque is given as;

$$T_e = \sqrt{M^2 + T^2} \tag{24}$$

where,

T_e is the equivalent torque

M is the maximum bending moment

T is the transmitted torque

$$\therefore T_e = \sqrt{242.0789^2 \times 20.1038^2} = 242.9122 \text{ Nm}$$

Also,

$$T_e = \frac{\pi}{16} \times \tau \times d^3 \tag{25}$$

where,

τ is the torsional shear stress the shaft is subjected to, and

d is the diameter of the shaft

But $\tau_{max} = 42 \text{ MPa}$ for shafts with allowance for keys [14]

$$\therefore 242.9122 = \frac{\pi}{16} \times \tau \times d^3; \Rightarrow d = \sqrt[3]{\frac{16 \times 242.9122}{\pi \times 42 \times 10^6}} = 0.0308833 \text{ m} = 30.8833 \text{ mm}$$

Also, the equivalent moment is given as;

$$M_e = \frac{1}{2} [M + \sqrt{M^2 + T^2}] \quad (26)$$

where,

M_e is the equivalent bending moment

$$\therefore M_e = \frac{1}{2} [242.0789 + \sqrt{20.1038^2 + 242.0789^2}] = 242.4956 \text{ Nm}$$

But,

$$M_e = \frac{\pi}{32} \times \sigma_b \times d^3 \quad (27)$$

where,

σ_b is the working stress (tensile or compressive)

$\sigma_{bmax} = 84 \text{ MPa}$ for shafts with allowance for keys [14]

$$\therefore d = \sqrt[3]{\frac{32 \times 242.4956}{\pi \times 84 \times 10^6}} = 0.0308656 \text{ m} = 30.8656 \text{ mm.}$$

The diameter in each case is almost the same. Therefore a diameter 40 mm is selected. For shafts of diameters between 25 mm and 60 mm, the steps for shoulders should be 5 mm [14]. Therefore, the larger diameter is taken as 40 mm and the smaller diameter as 35 mm.

3. RESULTS AND DISCUSSION

The millet thresher mainly employs the effects of friction (taking advantage of the fact that millets can be effectively threshed by rubbing the panicles on a rough surface) for threshing. The millet thresher has a thresher welded to a steel shaft and then supported on a frame. There is an input mounted on the thresher and an output fitted to the exit. The output comprises a sieve and a tray. A centrifugal fan supported on the frame supplies air that winnows the threshed grain coming out of the tray and the cleaned millet grains fall into a collector. Fig. 2 shows the isometric and orthographic views of the millet thresher while Fig. 3 shows the exploded view of the proposed design of the millet thresher. Fig. 4 shows the operational sequence of the proposed design. The thresher rotates in the anticlockwise

direction at a speed of 950 revolutions per minute. Malleable cast iron was selected for the design of the drum for maximum output. Medium carbon steel for the shaft offers a range of properties after quenching and tempering and therefore will be able to withstand stresses and deflections. The values of the parameters calculated are reasonable. The diameter of the shaft is calculated using the equivalent torque and equivalent bending moment and the results are 30.88 mm and 30.87 mm respectively which are reasonable.

4. CONCLUSION

A community based millet thresher to reduce the burden farmers go through in threshing pearl millet has been designed. The millet thresher would be a relief to farmers particularly women in the rural communities who would now rechanneling those long laborious hours spent in threshing millets into other productive ventures. The quality of the grains will improve since the possibility of wind introducing foreign materials into the millet is reduced. This design will reduce the stresses caused by manual hand threshing method which is a slow and laborious process. It will also reduce the damage caused to the seeds. This will invariably increase food production and improve the economy.

ACKNOWLEDGEMENTS

The authors of this paper acknowledge Atuah Jeremiah for his contributions, feasibility study, design draft and advice towards the success of this work.

COMPETING INTERESTS

Authors have declared that no competing interests exist.

REFERENCES

1. Obilana AB. Overview: Importance of Millets in Africa. AFRIPRO Proceedings on the Proteins of Sorghum and Millets: Enhancing Nutritional and Functional Properties for Africa, Belton PS, Taylor JRN. (Eds.), Pretoria, South Africa. 2003;26- 43.

2. Crawford GW, Lee GA. Agricultural origins in the Korean Peninsula. *Antiquity*. 2003; 77(295):87-95.
3. Spencer DSC, Sivakumar MVK. Pearl millet in African agriculture. Proceedings of the International Pearl Millet Workshop, Witcombe JR, Beckerman SR. (Eds.), ICRISAT Center, India. 1986;19-31.
4. Brian R. The physics of threshing pearl millet: Finding a revolutionary* solution to an ancient problem; 2008. www.millet.wetpaint.com
Accessed: January 20, 2013
5. Akinwonmi, Andoh. Design of a cassava uprooting device. *Research Journal of Applied Sciences, Engineering and Technology*. 2013;5(2):411-420.
6. Moser T, Wittel J, Schlafly P, Schmidt D, Shotyk B, Shotyk K, Scalzo M, Scalzo G, Scalzo A. Pedal-Operated Threshing Machine; 2010. Pub. No.: US2010/0298037 A1
7. Satzler RL. Supporting system for rotating concave grain threshing mechanism; 1998. Pub. No.: 5,803,807
8. Adewumi BA, Ademosun OC, Ogunlowo AS. Design, fabrication and preliminary testing of a thresher –cleaner for grain legumes. *J. Food Sci & Tech*. 2007;37: 276-280;
9. El-Haddad WZ, Shoughy MI, El-Kewey AL, Abo El-Hana NH. Development of local made machine model El-Haddad-wz to suit threshing and separation faba bean crop. *Mysore J. Agri. Eng*. 2006;23(4):943-962.
10. Smith FW, Hashemi J. *Foundation of Materials Science and Engineering*. McGraw-Hill Companies, Inc., 1221 Avenue, New York, America, 4th Ed; 2006.
11. Ross W Irwin. The sylvester auto-thresher: A Canadian first in grain harvesting. *Journal of the History of Canadian Science, Technology and Medicine*. 1984;8(2).
12. Bolton, W. *Newness Engineering Materials Pocket Book*. Butterworth-Heinmann, Linacre House, Jordan Hill. Oxford OX2 8DP 225 Wildwood Avenue, Woburn, MA 01802-2041, 3rd Ed.; 2000.
13. Budynas RG, Nisbett JK. *Shigley's mechanical engineering design*. McGraw Hill, new York, America, 9th Ed. 2011;1088.
14. Khurmi RS, Gupta JK. *A Textbook of Machine Design*. Eurasia Publishers, New Delhi. 2005;1230.

© 2019 Akinwonmi et al.; This is an Open Access article distributed under the terms of the Creative Commons Attribution License (<http://creativecommons.org/licenses/by/4.0>), which permits unrestricted use, distribution, and reproduction in any medium, provided the original work is properly cited.

Peer-review history:
The peer review history for this paper can be accessed here:
<http://www.sdiarticle3.com/review-history/46538>