



Design of Adaptive Control System Based on Model Reference Stick Slip Vibration

Huang Xun¹, Yang Xiao^{1*}, Li Jianghong² and Li Changhao³

¹Shaanxi University of Science and Technology, Xi'an, 710021, China.

²Northwestern Polytechnical University, Xi'an, 710072, China.

³Shandong University, Weihai, 264209, China.

Authors' contributions

This work was carried out in collaboration between all authors. Author HX designed the study, performed the statistical analysis, wrote the protocol and wrote the first draft of the manuscript. Authors YX and LJ managed the analyses of the study. Author LC managed the literature searches. All authors read and approved the final manuscript.

Article Information

DOI: 10.9734/CJAST/2017/38422

Editor(s):

(1) Dr. Koji Nagata, Professor, Department of Physics, Korea Advanced Institute of Science and Technology, Daejeon, Korea.

(2) Athanasios N. Petridis, Professor, Department of Physics and Astronomy, Harvey Ingham Hall, Drake University Des Moines, Iowa, USA.

Reviewers:

(1) Shashidhar K. Kudari, CVR College of Engineering, JNT University, India.

(2) Kanjuro Makihara, Tohoku University, Japan.

Complete Peer review History: <http://www.sciencedomain.org/review-history/22566>

Original Research Article

Received 25th November 2017

Accepted 29th December 2017

Published 2nd January 2018

ABSTRACT

The stick-slip vibration is a common vibration mode of the drill string system during the drilling and it is extremely destructive. The drilling efficiency will be greatly reduced, if the drill gets a bit damaged and the drill rod breaks when the stick-slip vibration occurs. In order to solve this problem, a two-degree-of-freedom focused mass model was established. The controller based on the model reference adaptive control method was designed. The simulation experiment was completed to prove the rationality of the established stick-slip vibration model and the correctness of the control method. The control equipment was developed and the tests above on the well were completed. The experimental results shows that the designed stick-slip vibration control system has validity and stability.

Keywords: Stick-slip vibration of drill string; adaptive control; feedback control; control system; mechanical model; model reference.

*Corresponding author: E-mail: 794264077@qq.com;

1. INTRODUCTION

Stick-slip vibration of the drill string [1-4] is a vibration mode that "movement - still - moving again - and then stationary". The stick slip vibration of the drill string will cause the drilling efficiency to be greatly reduced, the drilling rod breaks, the bit damage, the drilling speed is reduced, and the drill tool fatigue failure and other failures. At present, there are many researches in the field of stick slip vibration control in drill string abroad. Among them, Lin et al. [5] adopted dynamic synovial control method to solve the problem of drill bit stuck. Eva et al. [6] designed a discrete control method based on the angular velocity of the upper part of the drill string, the torque of the bit and the weight-on-bit; Hiddabi et al. [7] designed a full-scale controller based on the elastic-mass model. However, there are few researches on stick-slip vibration control in drill string in China. However, the research on stick-slip vibration control of drill string in China is less.

The oil well environment in the process of oil drilling is complicated and changeable, which leads to the model of the drill string system cannot be accurately obtained and brings difficulties to the stick-slip vibration control of the drill string. However, the adaptive control can handle the uncertainty of the model parameters well without completely knowing the model of the controlled object [8]. Model reference adaptive control and self-tuning regulator are two types of adaptive control systems which currently more mature [9]. In this study and research, the stick-slip vibration control system was designed based on the model reference adaptive control method [10], the experiments were completed above on the well and the experimental results were satisfactory. The domestic research on stick-slip vibration control is still in the initial stage. Therefore, the development of stick-slip vibration control system of drill string has the important practical significance to improve the level of our country's oil drilling technology.

2. DRILLING SYSTEM DYNAMICS MODEL ESTABLISHED

The drill string system is equivalent to a double focused mass-spring system, the top drive turntable and the drill assembly is considered as two upper and lower concentrated masses torsion model and established the drill string system model. Drill string system differential equations are as follows:

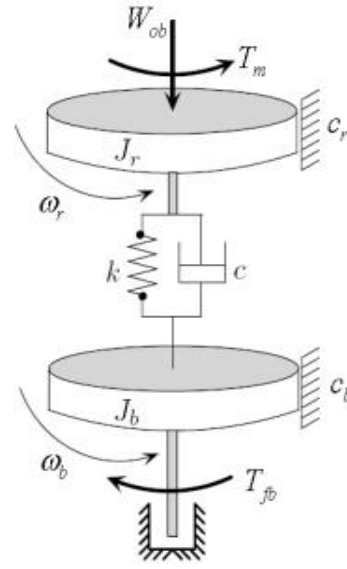

Fig. 1. Lumped mass model with two degrees of freedom for drill string system

$$\begin{cases} J_r \ddot{\varphi}_r + c(\dot{\varphi}_r - \dot{\varphi}_b) + k(\varphi_r - \varphi_b) + c_r \dot{\varphi}_r = T_m \\ J_b \ddot{\varphi}_b + c(\dot{\varphi}_b - \dot{\varphi}_r) + k(\varphi_b - \varphi_r) + c_b \dot{\varphi}_b = -T_f(x) \end{cases} \quad (2-1)$$

In Equation (2-1) J_r is the top drive turntable moment of inertia, in the article all the suffixes of r means rotary; J_b is the bit moment of inertia, in the article all the suffixes of b means bottom; c_r is the top drive damping coefficient; c_b is the drill damping factor; φ_r is top disc angle displacement; φ_b is the bit angular displacement; c is the equivalent damping coefficient of two degree of freedom concentrated mass model; k is the equivalent stiffness coefficient of two degree of freedom focused mass model; T_m is the motor drive torque, the suffixes of m means motor; T_f is the nonlinear term for friction torque, the suffixes of f means friction. Take the state variable as: $p = [\omega_r, \omega_b, \Delta\phi]^T$, this p represents the state variable of the drill string system.

$\Delta\phi = \varphi_r - \varphi_b$, as for the drill string system, its two degree of freedom focused mass model becomes:

$$\begin{cases} \dot{\omega}_r = -\frac{c+c_r}{J_r}\omega_r + \frac{c}{J_r}\omega_b - \frac{k}{J_r}\Delta\phi + \frac{1}{J_r}T_m \\ \dot{\omega}_b = \frac{c}{J_b}\omega_r - \frac{c+c_b}{J_b}\omega_b + \frac{k}{J_b}\Delta\phi - \frac{1}{J_b}T_f \\ \Delta\dot{\phi} = \omega_r - \omega_b \end{cases} \quad (2-2)$$

When it is in the speed control mode, taken $\omega_r = \Omega$ as a fixed value, then equation (2-2) can be converted into:

$$\begin{cases} T_m = c(\Omega - \omega_b) + c_r\Omega + k\Delta\phi \\ \dot{\omega}_b = \frac{c}{J_b} - \frac{c+c_b}{J_b} + \frac{k\Delta\phi}{J_b} - \frac{T_f}{J_b} \\ \Delta\dot{\phi} = \Omega - \omega_b \end{cases} \quad (2-3)$$

3. MODEL REFERENCE ADAPTIVE CONTROL

The design of the control system structure shown in Fig. 2. When the inverter works in the speed control mode, the feedback system (such as the current loop and speed loop in Fig. 2) formed by the motor and the inverter is mainly used to adjust the motor torque so that the motor speed remains unchanged. I and W are the current real-time current and speed of the motor respectively, and they are used as the input of the stick-slip vibration control system. Top drive the existing electronic control system (PLC controller) output as the main given input speed of inverter, stick-slip vibration control system output as a speed of the inverter given a given input. After the

frequency converter control makes the speed of auxiliary given zero, thereby suppressing stick-slip vibration.

Drilling model reference stick-slip vibration adaptive control system shown in Fig. 3: (1) The reference model is a physical model of the same nature as the system itself and is used to find the speed of the drill bit y_m ; (2) Top drive electric control system output current I and speed W as the input of the estimator to estimate the true bottom hole bit speed y_0 . When stick-slip vibration does not occur, the value of y_0 equals the value of y_m equal to the system main setpoint speed u . When stick-slip vibration occurs, the force between the drill bit and the rock can vary, so the real bit speed y_0 is a variable. When the true speed of drill bit y_0 is not equal to model reference output y_m , the system has generalized error $e = |y_m - y_0|$, using the controller to adjust the parameters of the drilling system, generalized error tends to zero. Finally, the true speed of the drill bit is approached to the output of the reference model, thereby suppressing stick-slip vibration.

The controlled object can be described as:

$$\begin{cases} \dot{x}_p = A_p x_p + b_p u \\ y_p = h^T x_p \end{cases} \quad (3-1)$$

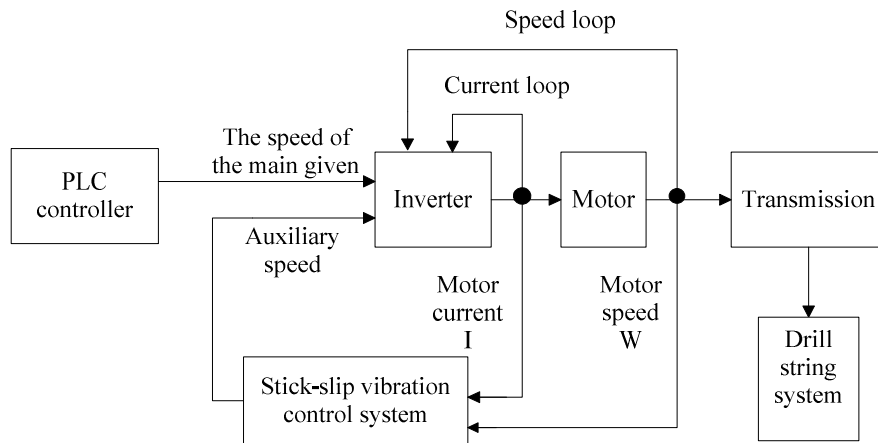

Fig. 2. Structure diagram of the control system

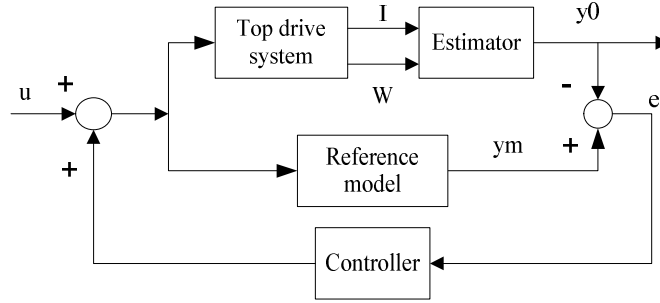

Fig. 3. Drilling model reference adaptive control system diagram of stick slip vibration

In equation (3-1) x_p is the dimensional state vector, A_p is the $n \times n$ matrix; b_p is the $n \times 1$ input vector; y_p is the output; $h^T = (1 \ 0 \ \dots \ 0)$ is the $1 \times n$ matrix, the suffixes of p means plant; the corresponding transfer function is:

$$W_p(s) = h^T (sI - A_p)^{-1} b_p = \frac{k_p N_p(s)}{M_p(s)} \quad (3-2)$$

In equation (3-2) $M_p(s)$ and $N_p(s)$ for the n -order and m -order polynomial, k_p is the controlled object gain. According to equation (2-2) take the state variable is: $q = [\omega_b, \Delta\phi]$, The q represents the state variables in this design of the control system, because this control system is speed control, so there is no speed variable in the state of this one. T_m is the output variable, equation (1-3) changes to:

$$\dot{q} = \begin{bmatrix} \dot{\omega}_b \\ \dot{\Delta\phi} \end{bmatrix} = \begin{bmatrix} \frac{c+c_b}{J_b} & \frac{k}{J_b} \\ -1 & 0 \end{bmatrix} \begin{bmatrix} \omega_b \\ \Delta\phi \end{bmatrix} + \begin{bmatrix} \frac{c}{J_b} \\ 1 \end{bmatrix} \Omega + \begin{bmatrix} \frac{T_f}{J_b} \\ 0 \end{bmatrix} \quad (3-3)$$

Since the friction torque is constant at steady state, the equation of state can be transformed into:

$$\dot{q} = \begin{bmatrix} \dot{\omega}_b \\ \dot{\Delta\phi} \end{bmatrix} = \begin{bmatrix} \frac{c+c_b}{J_b} & \frac{k}{J_b} \\ -1 & 0 \end{bmatrix} \begin{bmatrix} \omega_b \\ \Delta\phi \end{bmatrix} + \begin{bmatrix} \frac{c}{J_b} \\ 1 \end{bmatrix} \Omega \quad (3-4)$$

$$A = \begin{bmatrix} -\frac{c+c_b}{J_b} & \frac{k}{J_b} \\ -1 & 0 \end{bmatrix}, \quad b = \begin{bmatrix} \frac{c}{J_b} \\ 1 \end{bmatrix}$$

Then substituting A and b into the equation (3-2), the transfer function is:

$$W_p(s) = \frac{cs + k}{J_b s^2 + sc + sc_b + k} \quad (3-5)$$

Substituting the values in [11] into (2-5), then $W_p(s) = \frac{23.2s + 473}{374s^2 + 73.2s + 473}$. The corresponding controller structure shown in Fig. 4:

In the figure, y_r (the suffixes of r means reference) and y_m (the suffixes of m means model) are the reference model input and the reference model output, respectively. k_0 is adjustable gain. F_1 and F_2 are two auxiliary signal generators. c, d, d_0 are adjustable parameter vector. e_1 is the system generalized state error. G is the $n \times n$ matrix. v_1 and v_2 are the state vectors of the auxiliary signal generator, respectively. w_1 and w_2 are the output of two auxiliary generators respectively.

Fig. 4 shows that the controlled object can be expressed as:

$$u = k_0 y_r + w_1 + w_2 = k_0 y_r + c^T v_1 + d_0 y_p + d^T v_2 = \theta^T \phi \quad (3-6)$$

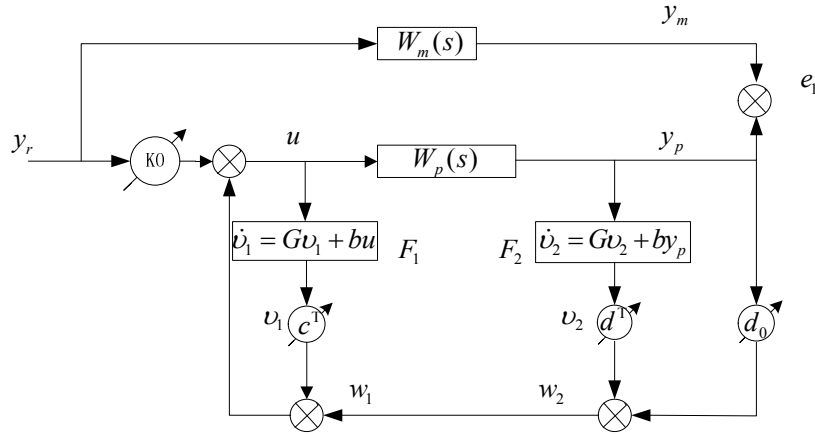

Fig. 4. Controller structure diagram

In equation (3-6), $\varphi^T = (y_r(t) \ v_1^T(t) \ y_p(t) \ v_2^T(t))$ and $\theta^T = (k_0 \ c^T \ d_0 \ d^T)$ are the signal vector and adjustable parameter vector of the controller respectively. Making $x = (x_p \ v_1 \ v_2)^T$, x is an adjustable system to augment state variables then:

$$\dot{x} = \begin{bmatrix} \dot{x}_p \\ \dot{v}_1 \\ \dot{v}_2 \end{bmatrix} = \begin{bmatrix} A_p & 0 & 0 \\ 0 & G & 0 \\ bh^T & 0 & G \end{bmatrix} \begin{bmatrix} x_p \\ v_1 \\ v_2 \end{bmatrix} + \begin{bmatrix} b_p \\ b \\ 0 \end{bmatrix} \theta^T \varphi(t) \quad (3-7)$$

Making $\theta(t) = \theta^* + \tilde{\theta}(t)$, in the equation θ^* represents the parameter vector when the adjustable system exactly matches the reference model. When the reference model and the adjustable system exactly match, at this time $k_0 \ c \ d_0 \ d$ are in the upper right corner with "" to show the difference.

$\tilde{\theta}(t)$ represents the parameter error vector. Substitute $\theta(t)$ into (3-6):

$$\theta^T \varphi = k_0^* y_r + (c^*)^T v_1 + (d^*)^T h^T x_p + (d^*)^T v_2 + \tilde{\theta}^T \varphi \quad (3-8)$$

Substitute (3-8) into (3-1), finishing extended state equation (in the article all the suffixes of c means compatible, A_c is an $n \times n$ matrix in an augmented state equation of an adjustable system.):

$$\begin{cases} \dot{x}_p = A_c x + b_c [k_0^* y_r + \tilde{\theta}^T \varphi] \\ y_p = h_c^T x = h^T x_p \end{cases} \quad (3-9)$$

When $\tilde{\theta}(t) = 0$, it means that $\theta = \theta^*$, the x_{mc} represents the reference model augmented state vector, x_m represents the reference model state vector. (3-9) can be expressed as (in the article all the suffixes of mc means model compatible):

$$\begin{cases} \dot{x}_{mc} = A_c x_{mc} + b_c k_0^* y_r \\ y_m = h_c^T x_{mc} = h^T x_m \end{cases} \quad (3-10)$$

The corresponding transfer function as:

$$W_m(s) = \frac{Y_m(s)}{Y_r(s)} = h_c^T (sI - A_c)^{-1} b_c k_0^* \quad (3-11)$$

$$e = x - x_{mc} = \begin{bmatrix} x_p - x_m \\ v_1 - v_{m1} \\ v_2 - v_{m2} \end{bmatrix} \quad \text{and} \quad e_1 = y_p - y_m$$

Making e , the extended state equation as:

$$\begin{cases} \dot{e} = A_c e + b_c [\tilde{\theta}^T(t) \varphi(t)] \\ e_1 = h_c^T (x - x_{mc}) = h_c^T e \end{cases} \quad (3-12)$$

Let e_1 and $\tilde{\theta}^T(t) \varphi(t)$ are the output and input of the error model, the transfer function of augmented error model is:

$$W_e(s) = h_c^T (sI - A_c)^{-1} b_c \quad (3-13)$$

Because $k_0^* k_p = k_m$ and $W_e(s) = \frac{k_p}{k_m} W_m(s)$, then $e_1 = \frac{k_p}{k_m} W_m(s) \tilde{\theta}^T(t) \varphi(t)$. Lyapunov function that is selected as this:

$$V = \frac{1}{2} (e^T P e + \tilde{\theta}^T \Gamma^{-1} \tilde{\theta}) \quad (3-14)$$

In equation (3-14) P , Γ are positive definite matrix. Derive t from (3-14), combined with extended state equation has:

$$\frac{dV}{dt} = \frac{1}{2} e^T (P A_c + A_c^T P) e + \tilde{\theta}^T \Gamma^{-1} \dot{\tilde{\theta}} + \tilde{\theta}^T \varphi b_c^T P e \quad (3-15)$$

Making $(P A_c + A_c^T P) = -Q$ and $\tilde{\theta}^T \Gamma^{-1} \dot{\tilde{\theta}} + \tilde{\theta}^T \varphi b_c^T P e = 0$, in that equation Q is a non-negative symmetric matrix, then $\frac{dV}{dt} = -\frac{1}{2} e^T Q e \leq 0$, adaptive regulation law is:

$$\dot{\tilde{\theta}} = \tilde{\theta} = -\Gamma \varphi b_c^T P e \quad (3-16)$$

$b_c^T P = h_c^T$, so adaptive law is:

$$\dot{\tilde{\theta}} = -\Gamma \varphi h_c^T e = -\Gamma \varphi e_1 \quad (3-17)$$

In equation (3-17) e_1 is measurable; φ is the semaphore is also known, so the adaptive law can be achieved.

4. SIMULATION

The simulation system structure (Fig. 5) was established according to the model reference adaptive control law and the literature [11] in the parameters. When the main given speed is 21 rad / s, the simulation results of motor torque, bit speed and control speed are shown in Fig. 6 (a), 6 (b) and 6 (c) respectively.

Fig. 6 (a) is a simulation diagram, is completed in an ideal state. The magnitude of the main speed reference in Fig. 6 (a) is empirically chosen and is given in international units, rad/s.

The analysis of Fig. 6 is summarized in Table 1:

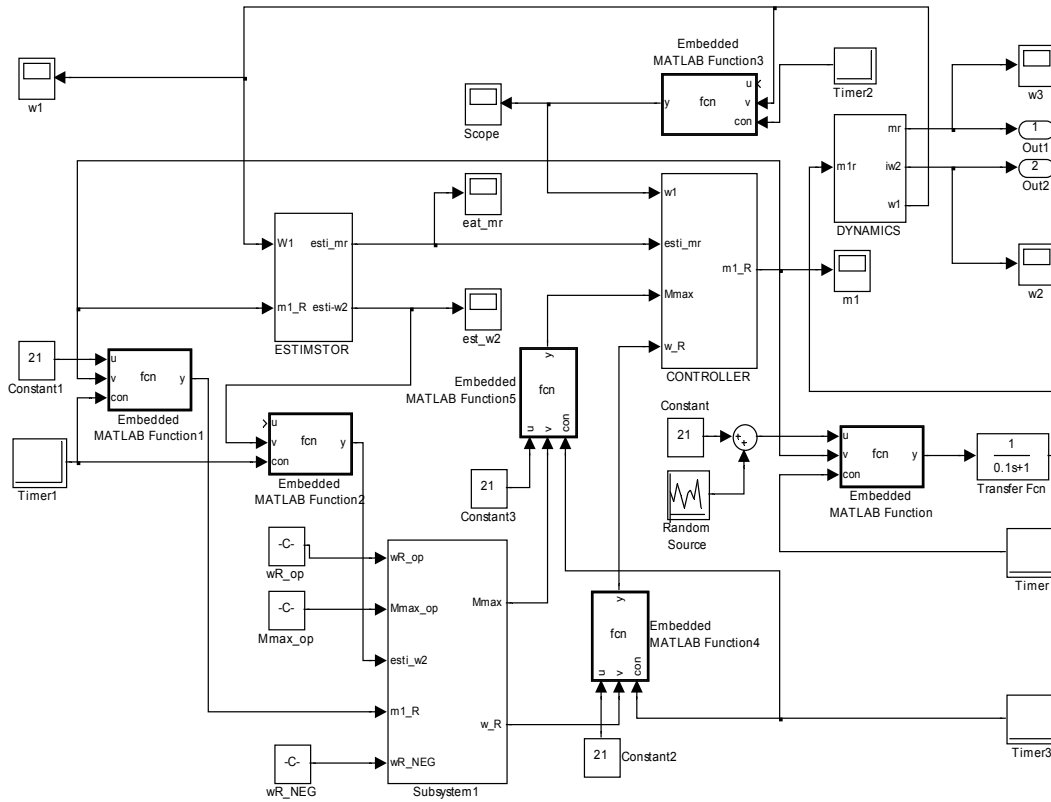

Fig. 5. Simulation model

5. EXPERIMENT

5.1 System Design

The experimental system was that made the drill string stick slip-vibration control system accessed to top drive electronic control system controlled the stick-slip vibration of drill string system. Stick-slip vibration control system (including human-computer interaction unit and control algorithm unit) was connected with external inverter through CAN bus which could realize the data exchange between inverter and control algorithm unit. The data exchange process was as follows: The actual motor speed and actual torque data acquired by the inverter were sent to the control algorithm unit through the CAN bus in time, the related parameters of the drill string system set in the display unit were transmitted to the control algorithm unit through the network cable. The speed control amount processed by the control algorithm unit was transmitted to the frequency converter through the CAN bus in a speed-assisted manner. Setting the speed which has set in the PLC controller as the main speed of the inverter. At the same time, the main setting of speed and the auxiliary setting of speed will act on the inverter to adjust the motor speed so as to restrain the stick-slip vibration.

5.2 Results and Analysis

During the experiment, the stick-slip vibration control system of the drill string was connected to the inverter for research, made Starter third-party online monitoring software to monitor the actual motor speed and actual torque detect the actual effect of the stick-slip vibration control system of the drill string. As shown in Table 2, the actual drilled drill string data, drilling depth 2948 m, (Drilling depth is equal to the length of the drill pipe, increasing the length of the drill pipe, drill collar and the length of the sum) the main speed of converter was given at 600 rpm, top drive motor gearbox reduction ratio of 12.5. In order to ensure the reliability of the experimental data, the experimental results of the motor actual speed, actual torque and auxiliary given speed (Table 3, Fig. 7) were obtained by the starter third-party online monitoring software.

The analysis of Fig. 7 is summarized in Table 3.

The data in Fig. 7 (a) is the motor speed in the actual drilling process. In the actual system, there will be various kinds of interference, so the motor speed will fluctuate under normal

Table 1. Summary of simulation results

Times Picture order	Before 1000 s	1000 s-1050 s	1050 s-1150 s
Fig. 6 (a)	Stick-slip vibration caused the motor torque fluctuations more intense.	After starting the stick-slip vibration control, the fluctuation of the motor torque gradually decreases during the control transition.	The motor torque gradually tends to be stable, and it is approximately equal to the desired torque 17548Nm.
Fig. 6 (b)	Stick-slip vibration causes bit speed fluctuations more intense, stick-slip vibration frequency of about 0.2 Hz.	The stick-slip vibration frequency of the drill bit was gradually reduced, and the stick-slip vibration was controlled.	Drill speed gradually stabilized, equal to the main given speed 21 rad/s.
Fig. 6 (c)	Since the stick-slip vibration control was not activated, the speed control was zero, the speed was maintained at 21 rad/s of the main setpoint.	The gradual decrease of speed control was the same with the change of bit speed.	After stick-slip vibration was controlled, the speed control was zero and the speed was approximately equal to the main given speed of 21 rad/s.

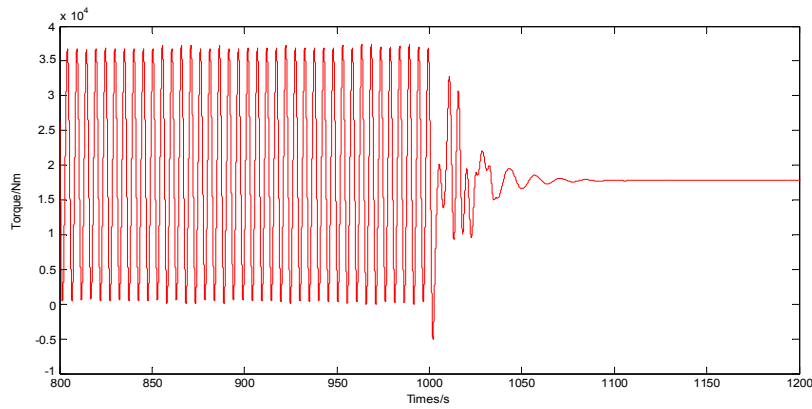

Fig. 6. (a) Motor torque

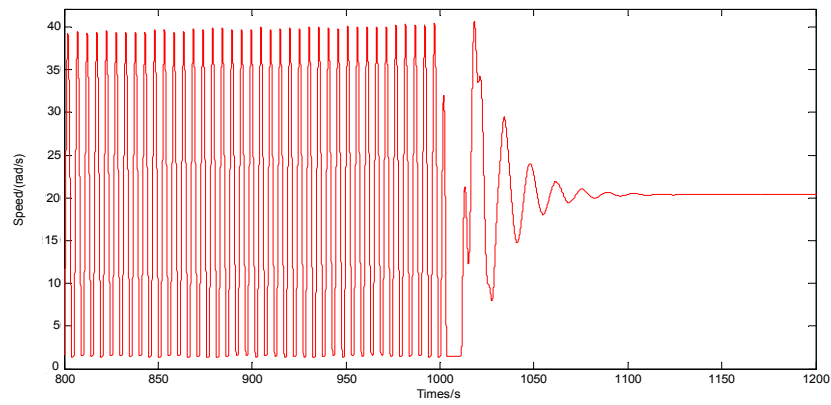

Fig. 6. (b) Bit rotation speed

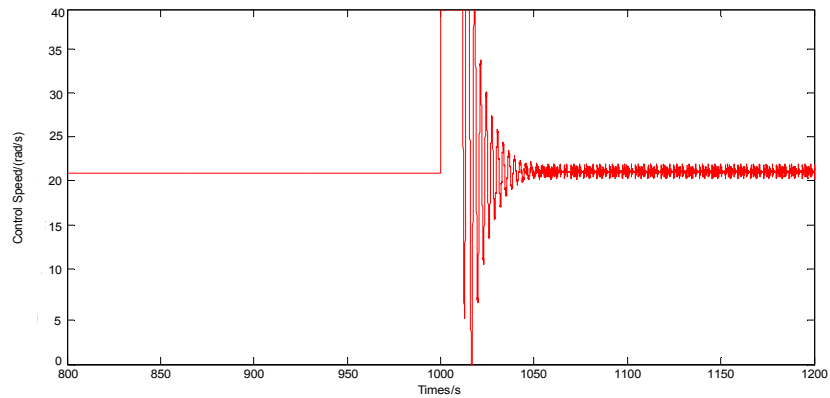

Fig. 6. (c) Control speed

conditions. The motor speed is the specific value of this experiment, the unit is RPM. Motor speed divided by the transmission ratio is the actual system of the main given speed. Between the two units can be converted to each other, $1 \text{ rad/s} = \pi/30 \text{ rpm}$.

It can be seen from the experimental results that the control system can give the auxiliary given speed in time when the stick-slip vibration control system is started. The combination of the given speed and the auxiliary given speed can effectively improve the stick-slip vibration,

restrain the drastic fluctuation of the top drive motor torque, and restore the drill string system to a balanced state in a short period of time. The

results show that the stick-slip vibration control system designed in this paper can effectively restrain the stick-slip vibration of drill string.

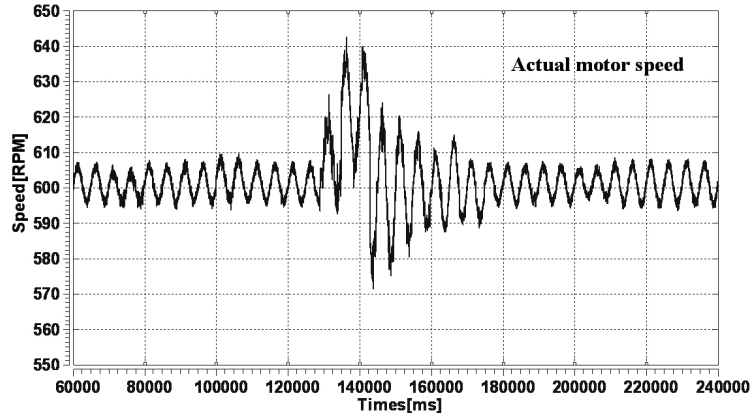

Fig. 7. (a) Actual speed of motor

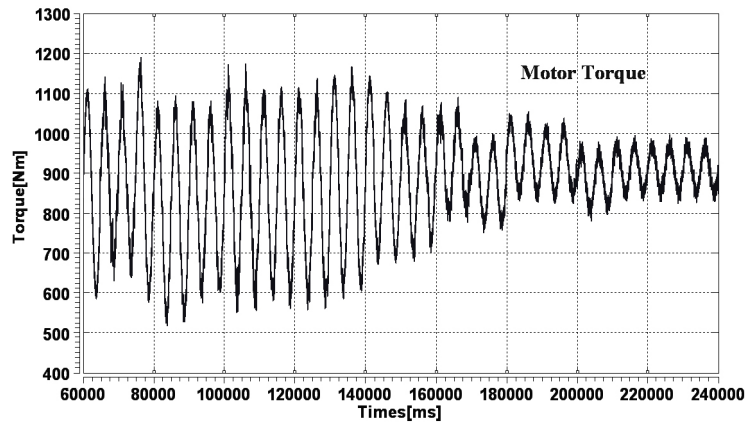

Fig. 7. (b) Motor torque

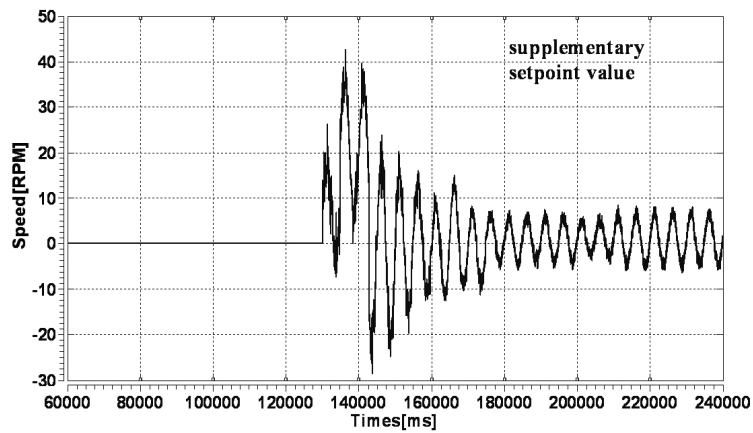

Fig. 7. (c) Auxiliary given rotation speed

Table 2. Structural parameters setting of drill string

Drill column components	Length /m	Outer diameter /m	Inside diameter /m
Drill pipe	2680	0.127	0.108
Increase the drill pipe	120	0.127	0.0762
Drill collar	148	0.2096	0.0715

Table 3. Summary of experimental results

Times Picture order	Before 130 s	130 s-180 s	After 180 s
Figure 7 (a)	The motor's actual speed fluctuation was small and vibration between 590 and 610 RPM.	Start stick-slip vibration control, controlled the actual motor speed during the transition large fluctuations in the vibration range of 580 ~ 640 RPM.	The motor speed fluctuates within the range of 590 ~ 610 RPM. After the control was applied, the trend of the motor speed and the auxiliary given speed was the same and equal to the speed of the motor before starting the stick-slip vibration control.
Figure 7 (b)	Stick-slip vibration caused the motor torque fluctuations more obvious, the value of about 600 ~ 1000 Nm between.	Start the stick-slip vibration control, the actual torque of the motor began to converge to the preset torque of 900 Nm, and the stick-slip vibration of the drill string was controlled.	The actual motor torque in the 800 ~ 1000 Nm within a small range, tended to the center value of 900Nm.
Figure 7 (c)	The stick-slip vibration control was not started so the auxiliary given output was zero.	Start stick-slip vibration control, auxiliary given speed was between -30 ~ 40 RPM vibration.	Auxiliary speed was equal to the total output motor speed minus the main given speed 600 RPM, the fluctuations in the vicinity of zero.

6. CONCLUSION

In this study, a dual-degree-of-freedom mass model of drill string system was established. An adaptive control system based on model reference was designed and simulated. Simulation results shows that the proposed control method can effectively suppress stick-slip vibration effectively. Finally, the actual control system works on a well was developed and the well site test was completed. The actual drilling data obtained from the third-party on-line monitoring software of starter showed that the designed control system can follow the changing rules of speed and torque, adjust the output speed of the inverter in time, and has better performance on the stick-slip vibration of the drill string inhibition. It plays a good guiding role in reducing the damage of drilling tools, increasing the drilling speed, improving the drilling efficiency and reducing the drilling accidents.

COMPETING INTERESTS

Authors have declared that no competing interests exist.

REFERENCES

1. Fu Meng, Li Jianghong, Wu Yafeng. Analysis of drill string stick slip vibration simulation and mechanism. Journal of Northwestern Polytechnical University. 2016;34(3):467-472.
2. Wang Jianping, Wang Dingfeng, Wang Xiongfei. Analysis of stick slip phenomenon of drilling tools and application of soft torque system in Chang Bei gas field. Petrochemical Application. 2012;31(12):51-55.
3. Feng Chengbao, Jia Xiaoli, Liu Shuhai. Research progress on stick slip vibration of drill string in oil and gas wells. Oil Field Equipment. 2016;45(11):78-87.
4. Han Chunjie, Yan Tie. Study on the stick slip law of drill string in extended reach well. Natural Gas Industry. 2004;24(11):58-60.
5. Yao-Qun Lin, Yu-Hua Wang. Stick-slip vibration of drill strings. Transactions of the ASME. 1991;113.
6. Eva M. Navarro-L'opez, Domingo Cort'es. Sliding-mode control of a multi-DOF oil well drill string with stick-slip oscillations, Proceedings of the 2007 American Control Conference Marriott Marquis Hotel at Times Square New York City, USA; 2007.
7. Al-Hiddabi SA, Samanta B, Seibi A. Non-linear control of torsional and bending vibrations of oil well drill strings. Journal of Sound and Vibration. 2003;265(2):401-415.
8. Li Junling, Yang Guanghong. Development and prospect of adaptive fault-tolerant control. Control and Decision Making. 2014;29(11):28-33.
9. Liu Xing, Liu Xiao. The development and application of adaptive control system. Internet of Things Technology. 2011;9:61-63.
10. Zhang Hongshuai, Wang Ping, Han Bangcheng. Rotor position detection of high speed permanent magnet synchronous motor based on fuzzy PI model reference adaptive. Chinese Journal of Electrical Engineering. 2014;34(12):1889-1896.
11. Gong Quancheng. Nonlinear characteristics analysis and robust control of stick slip vibration of drill string. Shannxi, Northwestern Polytechnical University. 2015;23-24.

© 2017 Xun et al.; This is an Open Access article distributed under the terms of the Creative Commons Attribution License (<http://creativecommons.org/licenses/by/4.0>), which permits unrestricted use, distribution, and reproduction in any medium, provided the original work is properly cited.

Peer-review history:
The peer review history for this paper can be accessed here:
<http://sciencedomain.org/review-history/22566>